

sfogliatrici automatiche - automatic dough sheeters



mod. SF 6514 A

Dati tecnici - Technical specifications	6514	6516	6520
Lunghezza A - Length A	3960-200*	4160-200*	4560-200*
Larghezza B - Width B	1035	1035	1035
Altezza C - Height C	1460-200**	1460-200**	1460-200**
Lunghezza nastri D - Belt length D	1400	1600	2000
Larghezza nastri E - Belt width E	650	650	650
Altezza piani da terra F - Work top height from floor F	945	945	945
Apertura massima cil. cal. - Meas. cylinder max. aperture	60	60	60
Diametro cil. cal. - Measuring cyl. diameter	80	80	80
Motori: potenza hp - Motors: power hp	1,5	1,5	2
Motori: assorbimento kw/h - Motors: absorption kw/h	1,1	1,1	1,5
Peso lordo kg - Gross weight kg	350	400	500
Peso netto kg - Net weight kg	330	380	480

* Considerare 200 mm in meno se la macchina è sprovvista di arrotolatore. - * Consider -200mm if your machine doesn't include winder

** Considerare 200 mm in meno se la macchina è sprovvista di sfarinatrice. - ** Consider -200mm if your machine doesn't include flour duster

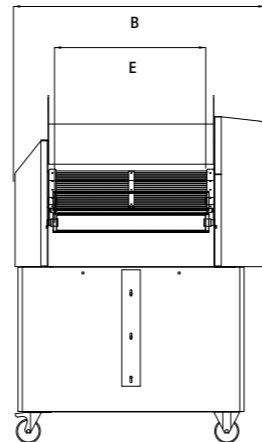
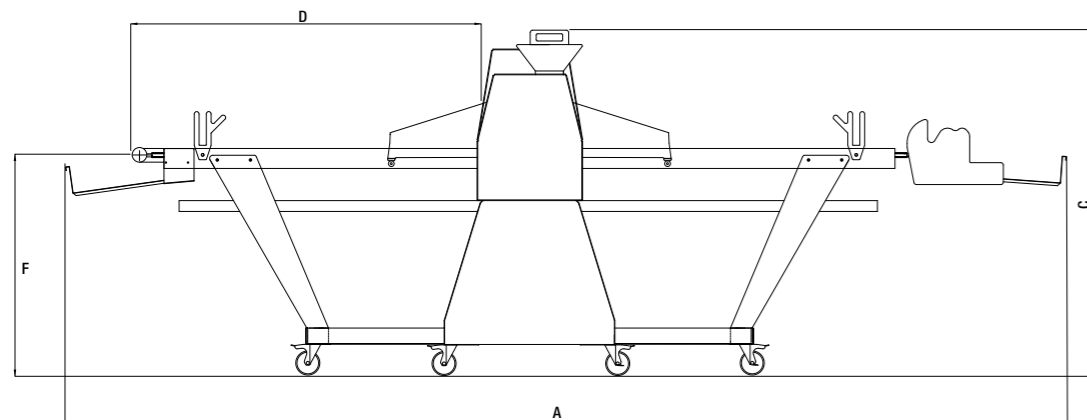

Z.Matik Pastry Machines - Via Fiesso, 4 - 35020 Z.I. Arre (PD) Italy - Tel. (+39) 049 9599935 - Fax (+39) 049 9501482
Web site: www.zmatik.com - E-mail: info@zmatik.com - Skype: z.matik.pastry.machines

Z.Matik la cui politica è quella di un continuo perfezionamento, si riserva il diritto di cambiare in qualsiasi momento i dettagli tecnici senza preavviso. - Due to technical progress, Z. Matik reserves the right to change technical features without notice



Italian Quality



automatic dough sheeters
SF A



sfogliatrici automatiche automatic dough sheeters

mod. SF 6514 A



Funzionalità, robustezza, semplicità d'uso: queste sono le essenziali componenti della nostra sfogliatrice. Macchina versatile ed affidabile, si adatta alle esigenze del medio e grande laboratorio. Tutti i modelli di macchina sfogliatrice automatica sono provvisti di pannello a colori touch screen 5,7" che permette di lavorare in tre differenti modalità: manuale/semiautomatico/automatico.

Questo fa sì che la programmazione della macchina sia facile e intuitiva da parte dell'operatore. E' possibile registrare 50 ricette con diversi cicli di lavorazione. La macchina può avere in dotazione lo sfarinatore e l'arrotolatore che permettono di velocizzare i tempi di lavorazione.



Our puff pastry machine is functional, sturdy and easy to use. It is a reliable piece of equipment which will adapt to the work requirements of medium and big productions. All the automatic models are equipped of 5,7" colored touch screen panel which allows to work in three modes: manual/semiautomatic/automatic.

In this way the machine's programming becomes easy and intuitive for the operator. It is possible to register 50 recipes with different production cycles. The machine can have as optionals the flour duster and winder that let to accelerate lavouration times.



display

Display a colori
Color display

Alcuni modelli di rulli per taglierina
Few models of cutting rollers

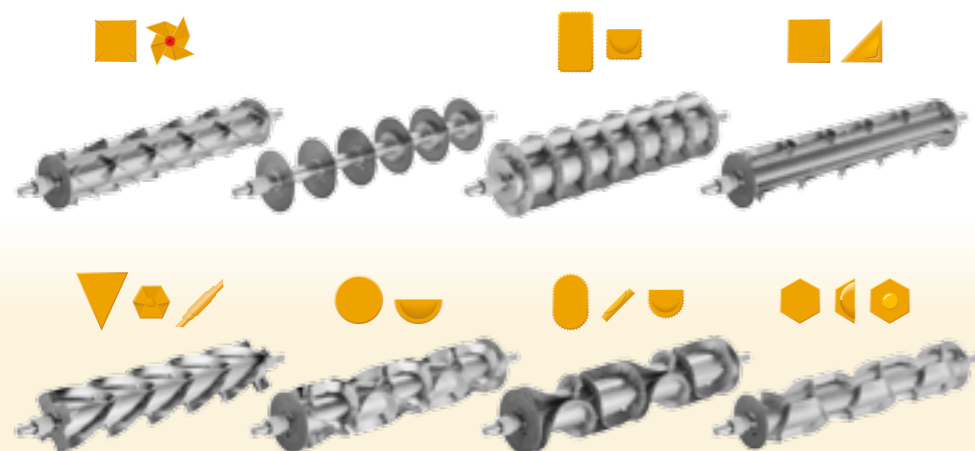

La stazione di taglio a due principi evita che la pasta si attacchi allo stampo.
The double seat cutting station avoids the dough to stick in the moulds.



sfarinatore

Sfarinatore automatico
Automatic flour duster



arrotolatore

Arrotolatore automatico
Automatic winder